

MISUTONIDA
italian style **4x4**
accessories

MITSUBISHI OUTLANDER 07



Item Code

Codice Articolo

Référence Article

: MED/200/IX
MED/K/200/IX

GB

STAINLESS STEEL
MEDIUM BAR









ITA

MEDIUM BAR
IN ACCIAIO INOX

FR

MEDIUM BAR
EN ACCIER INOX

MITSUBISHI OUTLANDER 07

Part List	
Lista della bulloneria	
Liste des pièces	
A	TE 8x30  x 2
B	Ø 8  x 4
C	Ø 8  x 4
D	M8  x 4
E	152  x 2
F	PARKER 6,2X25  x 2
G	VIPLA Piccole Small Petites  x 2
H	SMA/200/A  x 2

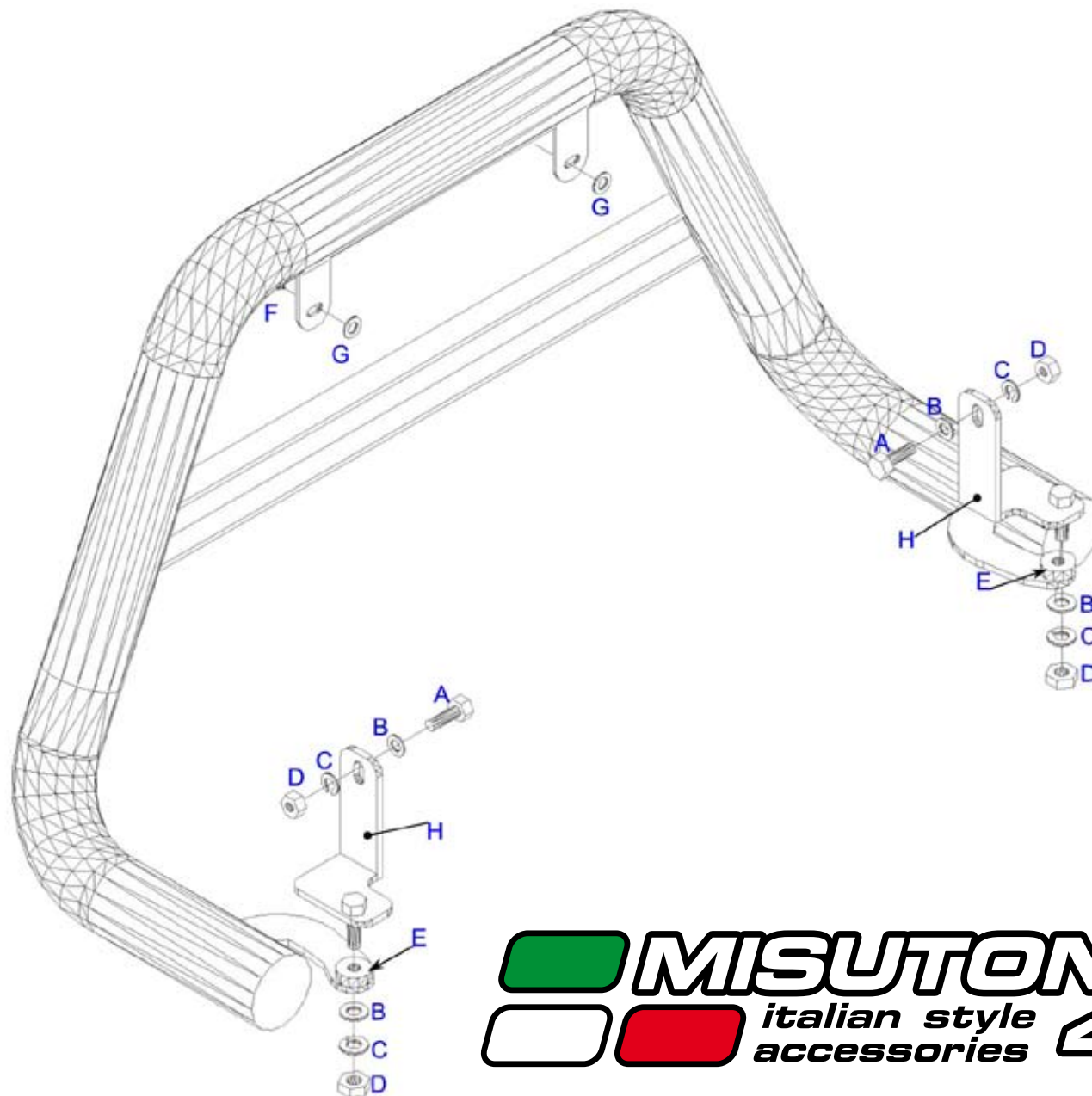

MISUTONIDA
italian style accessories **4x4**

GB**FITTING
INSTRUCTIONS**

1. Remove the plastic protection located in the lower part of the front bumper (picture 1).
2. Fit the H brackets in the hole indicated in picture 2 and in its correspondent on the opposite side.
3. Position the H brackets as shown in pictures 3 and 4 and fix them using A,B,C,D as shown in picture 5.
4. Fit back in place the plastic protection taking care of letting the bolts welded to the H brackets come out of it as shown in pictures 6 and 7.
5. Remove the numberplate holder
6. Fit the lower welded brackets on the bolts (on H brackets) previously fitted (picture 8) using B,C,D,E.
7. Fit the upper welded brackets in the holes used for the number plate holder using F,G (picture 9) and fit the numberplate holder at the same time.
8. Tighten all the set of bolts.

ITA**ISTRUZIONI DI
MONTAGGIO**

1. Rimuovere la protezione in plastica presente nella parte inferiore del paraurti (foto 1).
2. Montare le staffe H nei fori indicati nella foto 2 e nel suo corrispondente sul lato opposto.
3. Posizionare le staffe H come indicato nelle foto 3 e 4 e fissarle utilizzando A,B,C,D come indicato in foto 5.
4. Rimontare la protezione in plastica facendo fuoriuscire i bulloni saldati alle staffe H come indicato in foto 6 e 7.
5. Rimuovere il porta targa.
6. Montare le staffe saldate inferiori sui bulloni (saldati ad H) precedentemente fatti fuoriuscire dalla protezione in plastica (foto 8) utilizzando B,C,D,E.
7. Fissare le staffe saldate superiori nei fori occupati dal porta targa utilizzando F,G (foto 9), rimontando al tempo stesso il porta targa.
8. Serrare tutta la bulloneria.

FR**INSTRUCTIONS DE
MONTAGE**

1. *Enlever la protection en plastique qui se trouve dans la côté inférieure di parechoc (photo 1).*
2. *Monter les étriers H dans le trou indiqué dans la photo 2 et dans son correspondent de l'autre côté.*
3. *Positionner les étriers H comme indiqué dans les photos 3 et 4 et les fixer en utilisant A,B,C,D comme indiqué dans la photo 5.*
4. *Remonter la protection en plastique en faisant sortir les boulons soudés aux étriers H comme indiqué dans les photos 6 et 7.*
5. *Enlver le porte plaque d'immatriculation.*
6. *Monter les étriers soudés inférieures sûr les boulons précédemment faits sortir de la protection en plastique (photo 8) en utilisant B,C,D,E.*
7. *Fixer les étriers soudés supérieures dans les trous occupés par le porte plaque d'immatriculation en utilisant F,G (photo 9) et remonter le porte plaque dans le même temps.*
8. *Serrer toute la boulonnerie.*



Date Data Date	Item Code Cod.Articolo Réf. Article	Vehicle model Modello Veicolo Modèle de Voiture
04/04/07	MED/200/IX MED/K/200/IX	MITSUBISHI OUTLANDER 07

Checked and approved by
Controllato ed approvato da
 Controlé et approuvé par

**Claudio
 Gallo**

